

BUYTRICYCLE



ENJOY YOUR FREEDOM  
**SCOUT**<sup>®</sup>

## ASSEMBLY GUIDE

Spanish, French, German, Dutch, Italian, Portuguese,  
Polish :

[www.buytricycle.com/instructions](http://www.buytricycle.com/instructions)

BuyTricycle

Email: [help@buytricycle.com](mailto:help@buytricycle.com)

Twitter: @BuyTricycle

facebook: @BuyTricycle

Phone: +44 7856 715212

Thank you for purchasing from us, we have included a free battery light to keep you safe, a pump to keep you inflated & a cable lock & weather cover to keep your trike safe and dry!

**IMPORTANT** - Frame number can be found under the crank in the center of the trike.

Before your first ride, you must check the following items:

- Check all nuts and bolts are tight and none have become loose.
- Check that the handlebars, wheels, pedals and saddle are secure and adjusted to suit
- Check that you know how the gears and brakes operate and they are working sufficiently.
- Check that your tyres are inflated correctly.
- Please note that if the mudguards do not seem aligned, simply move them back into position and re-tighten the bolts.
- On folding models always make sure quick release system is secure and locked in place before ride.

## Build Instructions:

We've tried to make this booklet as user friendly as possible but it is only a guide, so please only attempt the build if you have experience with Tricycle / bicycle assembly, if not seek professional assistance. BuyTricycle will not be held responsible for accidents/injuries due to an improper build, but please do not hesitate to contact us with any questions you may have.

## Tools Required:

- **Spanner - included**
- Phillips and flat blade screwdrivers - **Included**
- Metric Allen Keys - **included**
- Pliers with cutting ability
- Bike chain tool/ splitter - **included**
- Bicycle Oil - **Recommended**
- Bicycle Grease - **Recommended**
- Bike/Trike Stand would be useful as elevation required



**IMPORTANT:** Carefully open your Tricycle box and remove packaging. Lay out all the separate components, all hardware is located in the small box, the nuts & bolts are in labeled bags, Please check for any faults on the tricycle/parts, if anything is missing then please contact us and we will arrange replacements immediately.

# ADULT TRIKE PARTS IDENTIFICATION

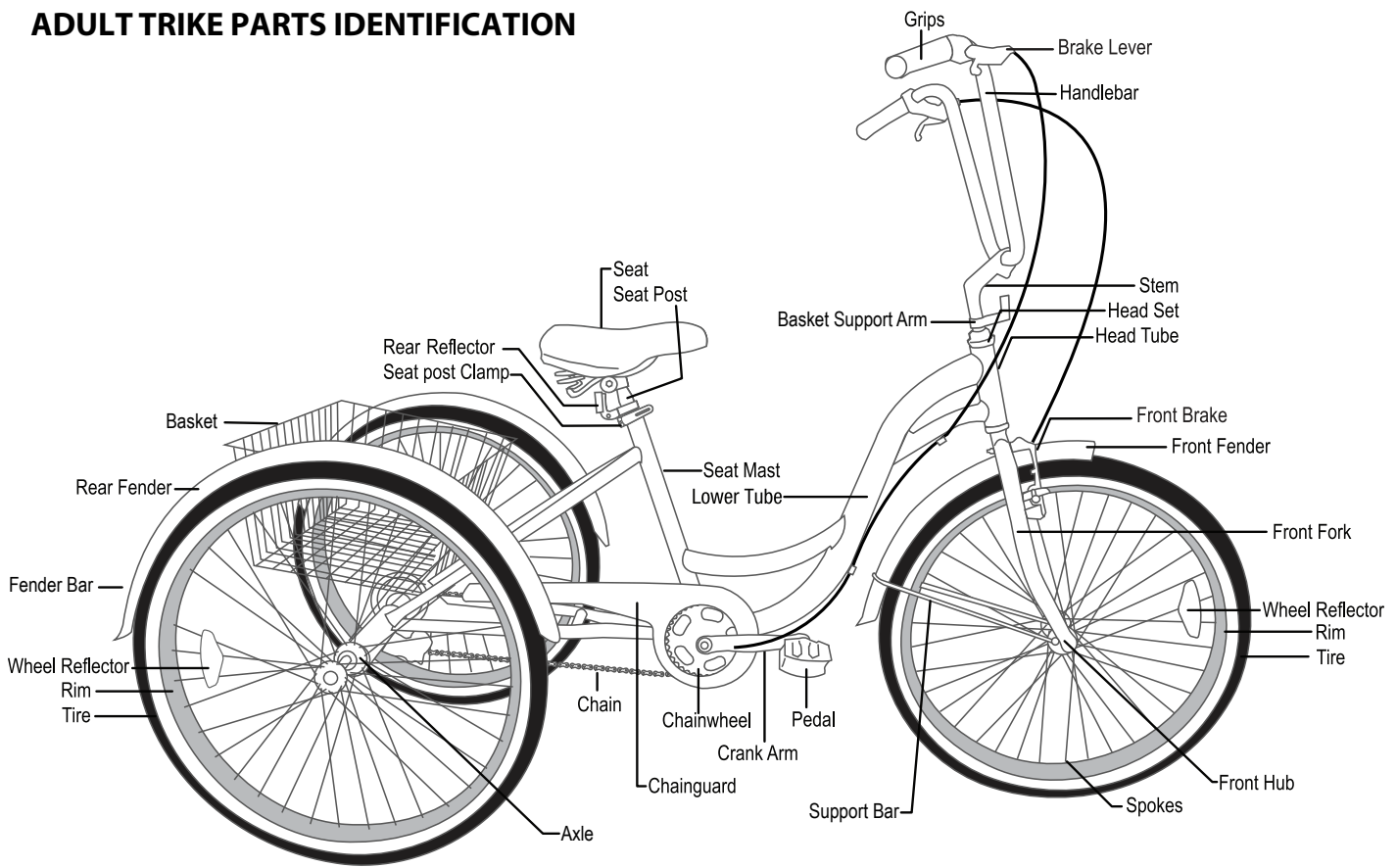

1. Begin by attaching the rear axle to the trike frame using the hardware provided (fig.1) and the **four bolts** already attached to the axle, 3 bolts either side, **4 bolts are pre-inserted in the axle, these may need to be loosened.**



Fig 1



2. **It is recommended to attach the rear mudguards before the wheels (step 11)** Attach the rear wheels, the right wheel has a different cut to the left, so ensure they fit onto the correct side.



The front wheel uses a quick release axle (fig 1a), this must be inserted through the wheel before placing the wheel into the forks and tightening the axle.

1a



## Fasten the wheel

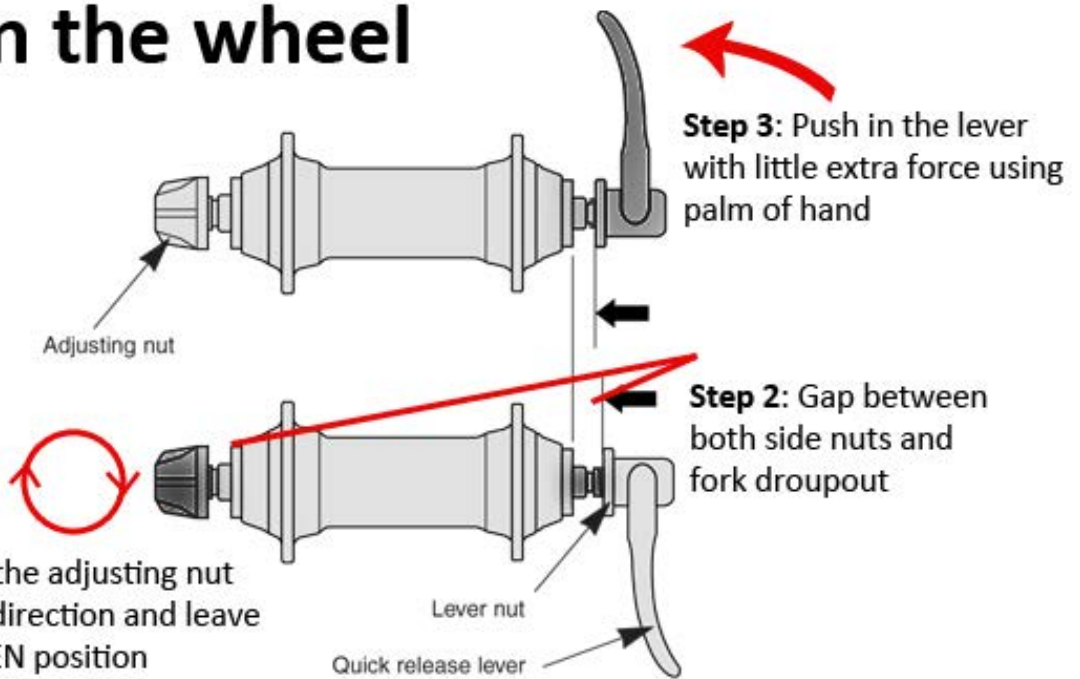

**3b.** Attach the front fender using hardware . **Fig 2**



**Fig 2**



Determine final closing position of lever. Rotate front lever and adjusting nut so the lever will end up just in front of fork. Reposition the lever as necessary if it will not fully close, **ensure fully closed before cycling.**

**FOR E-TRIKES ONLY**

**3.** Attach the front motor wheel. Check the directional arrows on the tyre to ensure it is the correct way. Motor cable will be on the same side as chain. (right) **Ensure this is extremely tight and the wheel spins freely.**



To fit the front wheel (Electric Wheel Hub) remove both plastic caps from the large nut either side of the tyre and loosen the bolt on each side, insert the wheel into the forks keeping the smaller washer outside the forks. (washer > locking washer > forks > washer > nut.

**3b. POWER CABLE (IMPORTANT)**

When joining your cable from the front electric wheel hub to the cable from your battery, ensure the two arrows meet as shown here. Once this is done use the tie wraps to secure the cable to the forks to keep it safe and tidy.

If the LCD screen shows error 03 then the cable is not inserted correctly.



4. Fit the chain over the chain wheel, through the rear gear cluster and the Shimano dérailleur and link together using a chain tool.



5. Attach the chainguard using the hardware in **Fig 3**.

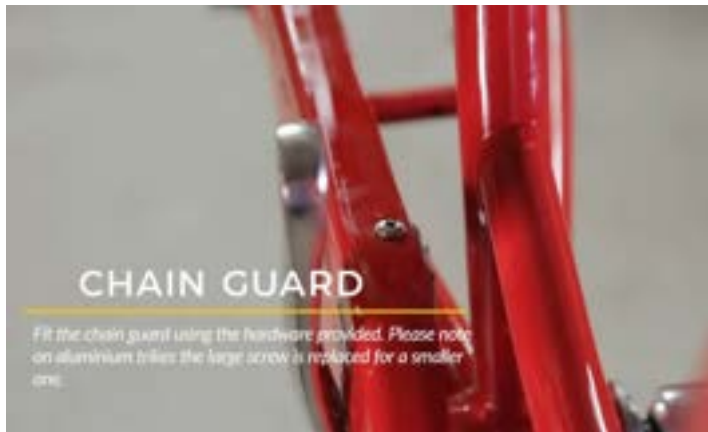

Fig 3



You can now proceed to attach the pedals, they are labeled L for the Left side and R for the right.

6. Attach the saddle to the seat pole and insert into the seat tube, tighten with the quick release hatch. Check for the minimum insertion mark on the tube, insert the tube so it is no longer visible.



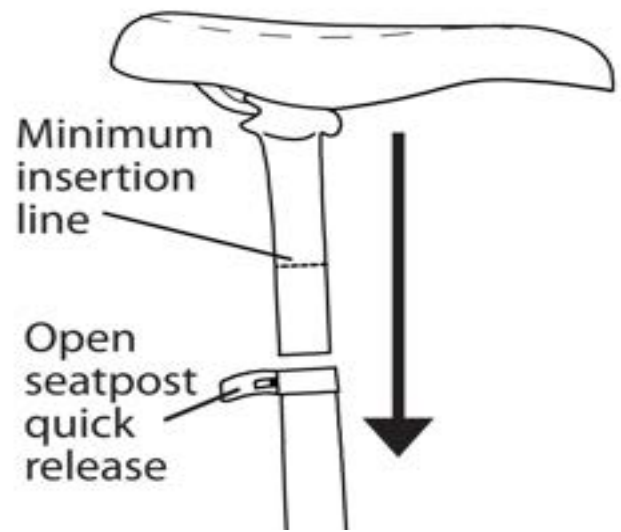
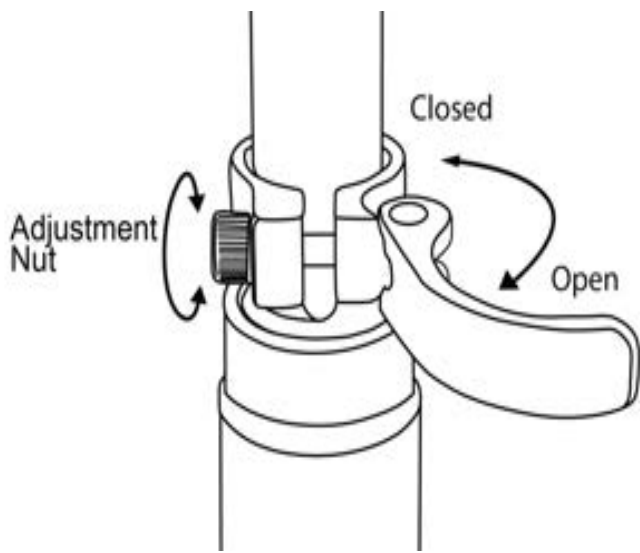

7. Insert the handlebars into the head-tube, tighten to the required height and angle. Check for the minimum insertion mark on the stem, insert the stem so it is no longer visible.



8. Fix the rear brake cable to the left hand lever, run the cable through the guide hole and along the trike to the rear disc brake.

The front just needs to be fitted to the right hand lever, it is pre-wired into the V-brake.

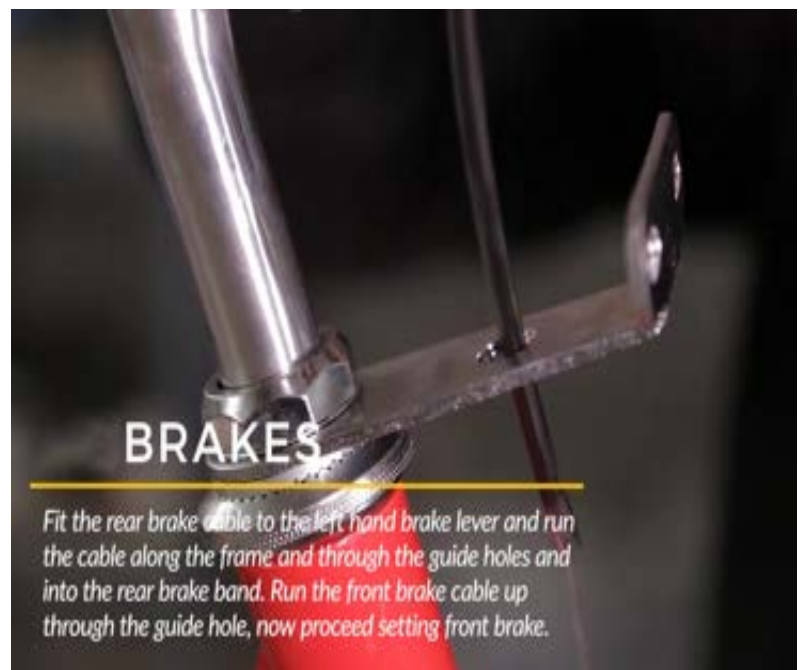

- 8a.** The rear cable should be fed into the rear disc brake as shown below, ensure the disc runs smoothly, pull the cable tight and tighten the brake.



## Front Disc brake

Feed the front brake cable down into the front caliper and tighten into place.

Test the wheel spins freely and adjust the brakes to ensure stopping capabilities.



- 8b.** With wire snippers shorten the excess front brake cable and fit cable caps ( Fig. 4). Then fit the cable caps to the rear brake cable and rear gear cable.



Fig 4

9. Time for the gears, feed the gear cable through the housing and pass it through the guide holes on the frame to the rear of the trike



Feed the cable into the derailleur, before tightening the gear cable in place, ensure you have set the max high and low screws, these screws limit the movement of the derailleur and stop it from coming off while changing gears, there is a very helpful video on our instructions page which will teach you how to set gears. [www.buytricycle.com/instructions](http://www.buytricycle.com/instructions)



## ADJUSTMENT - Rear Dérailleur:

The Low limit screw determines how far the rear derailleur will travel toward the wheel of the bicycle, while the High limit screw determines how far the cage will travel toward the frame.

1. Shift the rear shifter to the largest number indicated, and place the chain on the smallest sprocket.
2. Adjust the High limit screw so the chain and the smallest sprocket are lined up vertically. Remove any slack in the cable by pulling it taut, then connect the cable through the cable anchor and bolt securely. Some derailleurs have an adjusting barrel (see drawing). Use the adjusting barrel to fine tune the adjustment of the chain location. Turning the adjusting barrel clockwise will move the derailleur outboard - away from the wheel - while turning it clockwise will direct the chain inboard - towards the wheel.
3. Use the adjusting barrel to fine tune the adjustment of the chain location. Turning the adjusting barrel clockwise will move the derailleur outboard - away from the wheel - while turning it clockwise will direct the chain inboard - towards the wheel
4. Shift the chain onto the largest sprocket; adjust the low limit screw so the chain and the largest cog are lined up vertically. If you are unable to get the chain to the largest cog, turning the Low limit screw counter-clockwise will enable the chain to move towards the wheel.
5. Shift through the gears ensuring each gear is achieved quietly and without hesitation.

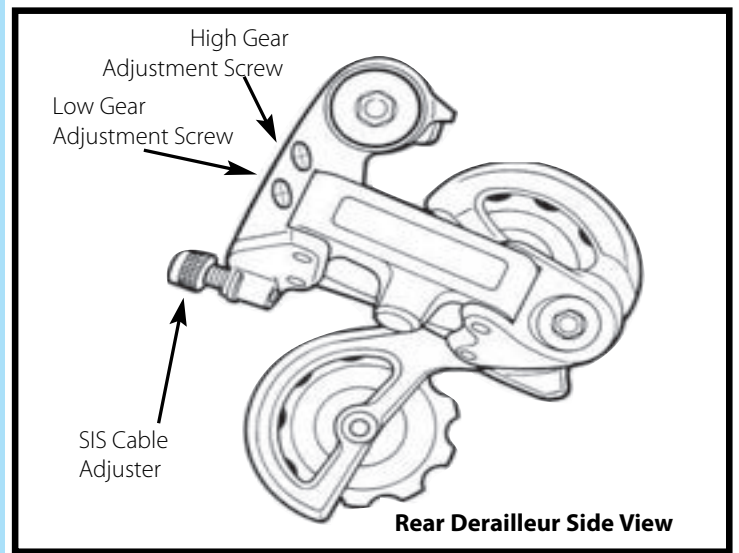
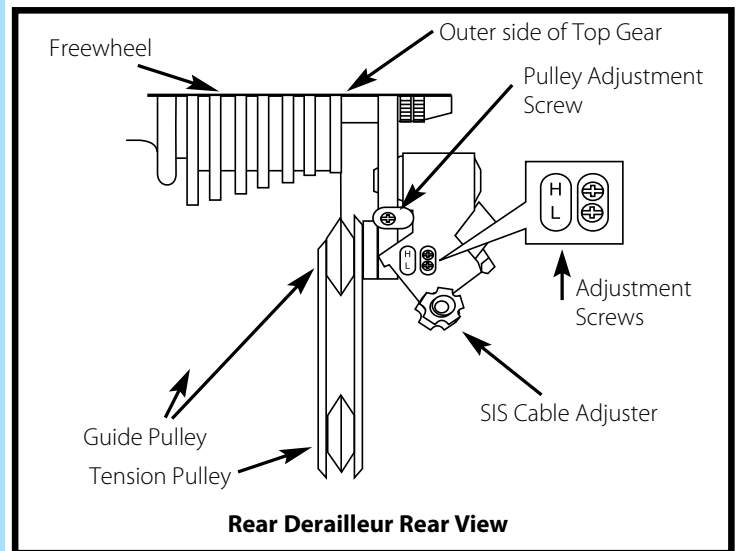

11. First, install the 2 rear reflectors in Fig A onto the mudguards, this must be done first because you will not have access after.



Fig A

You can now attach the rear fenders using the 6 chrome bars and hardware in fig B & C



Fig B

Attach these to the flat end of the chrome bar and attach onto trike x 3 each side.



Fig C

Attach these to the curved end of the chrome bar and onto the mudguard x 3 each side.

12. Almost done, just a few finishing touches now, begin by installing the front reflector followed by the wheel reflectors



#### Basket:

The basket uses the 2 white bars to attach through the rear axle using the hardware shown below.

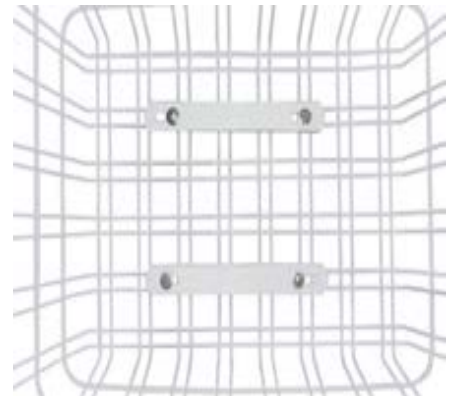
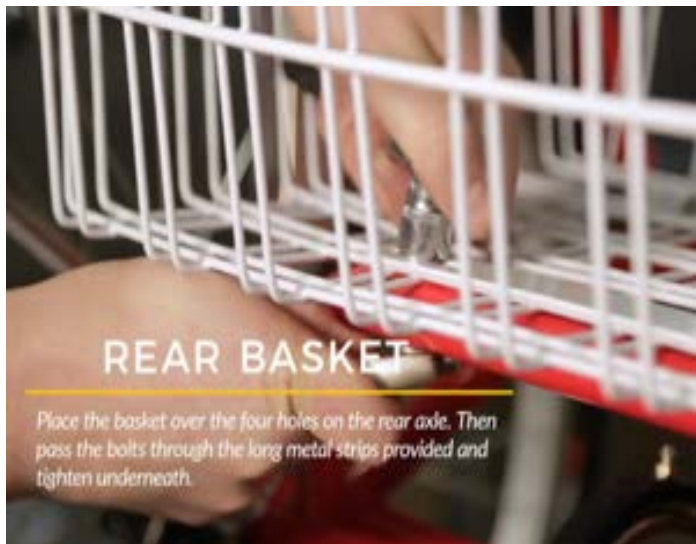

#### Folding the tricycle

To unfold the tricycle, release the quick release lever and lift handle, this will then allow the frame to be folded. Simply return the frame to its starting position and **lock the quick release lever back into place for the tricycle to be ridden.**



Our tricycles come with folding baskets, to secure them we supply them with plastic clips, instructions to install below

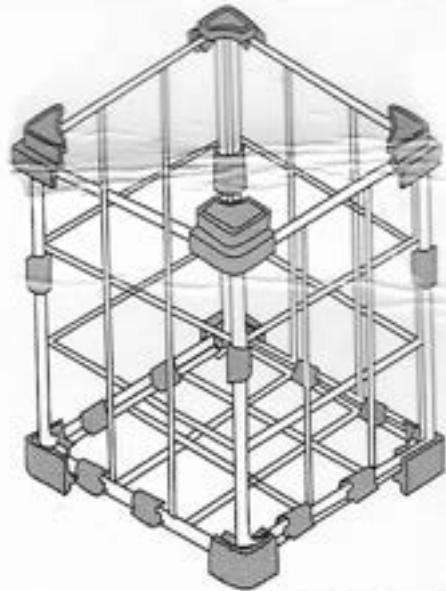
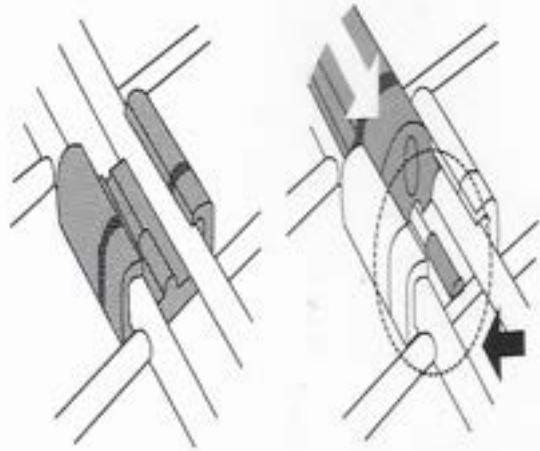
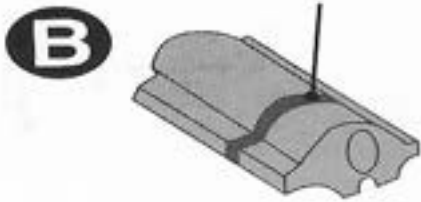
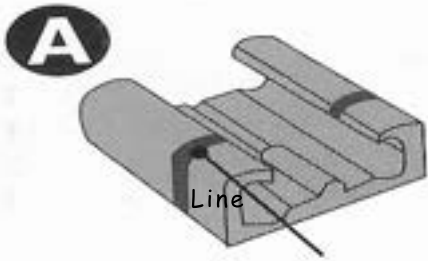

# PARTS LIST

AXLE HARDWARE X6  
4 ARE PRE-INSERTED INTO AXLE



CHAIN GUARD HARDWARE X3



FRONT FENDER HARDWARE



/ FENDER BAR top HARDWARE



FENDER BAR HARDWARE bottom X6



REAR BASKET HARDWARE X4



CABLE CAPS



REAR FENDER REFLECTORS



GEAR CABLE / REAR BRAKE CABLE



WHEEL REFLECTORS



PEDALS



FRONT WHEEL CAPS (electric trikes only)



Basket support bars x 2



Chain



Quick release axle (non electric models only)



Rear Mudguards



Seat post



Front Mudguard



### Charging instructions

1. Out of the box, the battery is only semi-charged. Charge to its full capacity before first use.
2. For the first three charges, charge the battery for at least 12 hours.
3. Put the female plug of the charger into charging socket of the battery box. Insert the male end of the plug into the outlet. The power is on when the indicator lamp of the charger is on.
4. When the light turns from red to green, the battery is fully charged.
5. After the green light is on, the charger is in “trickle charge” and will charge slowly and maintain the charge.

### E-TRIKES ONLY

Detachable Battery



Battery Charger



**ALWAYS KEEP 1 KEY SAFE, AS WE DO NOT KEEP SPARES,  
AND THEY ARE UNIQUE TO YOUR TRICYCLE.**

#### Caution:

1. Please make sure that the voltage in your country is suitable for the charger's input/output requirements.
2. Please ensure the e-trike power switch is off and the key has been removed before charging.
3. This charger is recommended for INDOOR use only.
4. When charging, please try to place out of reach of children.
5. Charger repairs should be carried out by a qualified technician – Do Not Attempt to Repair Yourself.
6. Do not touch the two electrodes on the battery by hand.
7. When the bike is not in use, charging the battery is still recommend at least once every month; for a minimum of two hours each time.
8. Only use this charger in a dry, clean, well ventilated environment out of direct sunlight.
9. Do Not Open the battery casing this will void your Warranty.

## BuyTricycle.com – Terms & Conditions

### Returns Policy –

A no quibble 14 day money back guarantee on all purchases. The buyer is responsible for the return postage costs and the product must be returned in an unused, re-saleable condition and in its original packaging and must include any extras. Any damages or wear and tear will be deducted from the refund.

Delivery costs will be deducted from the refund amount.

This does not affect your statutory rights.

### Damaged or faulty goods –

**IMPORTANT:** Please check the tricycle/ parts carefully before the build process as we cannot refund or replace on scratches and breakages once this has started. This does not affect mechanical fault issues.

Please check the items carefully and report any damages/fault and include a damage description, any comments made to the driver and photographs were necessary.

Customer satisfaction is our number one priority. If you receive your goods and they are damaged or faulty in any way, you must notify us immediately. We will then resolve the matter to your satisfaction.

Current consumer protection legislation states that items must be as described, fit for purpose and of satisfactory quality. If you purchase a product online which is found to be faulty within 30 days then you are entitled to request a full refund of the faulty product. Should a fault occur after the initial 30 days, we are entitled to repair and/or replace that item (see 1 year parts warranty). If it cannot be repaired or replaced, then you may be entitled to a refund. Advice about your legal rights is available from your local Citizens' Advice Bureau or Trading Standards office.

If a return is requested due to a fault or damage not caused by the customer, the item must be returned in the original packaging with any extras.

Any damages which have not been prior notified, proof of build or have been caused by damage in transit due to poor packaging this will be deducted from the refund. It is the buyers responsibility to ensure safe return of any items.

**BuyTricycle** will arrange 1 free returns collection on a date convenient to the customer. If the delivery is missed no more free collections will be arranged and any further collection charges will be deducted from the refund.

If the tricycle or any accessories are returned and damage or fault has been caused by the customer due to deliberate damage, wear and tear, or attempted builds **BuyTricycle** will write a report and include cost of repair or replacement, which will then be deducted from the refund along with any returns postage costs.

We will not accept rust/weather damage as a fault and it will not be covered in the warranty. It is the buyers responsibility to ensure the tricycles care and maintenance. Please refer to our cycle maintenance page for tips and advice.

### Delivery –

Free standard delivery on all UK mainland orders only.

One free delivery per order. If delivery is refused by the delivery address the re-delivery of the item will be the buyers responsibility.

Postage charges apply if purchasing in Northern Ireland, Highlands, Non Mainland Areas, British Isles, Republic of Ireland and Europe (Buyers outside the UK are reminded that the currency is GBP). Please see drop down box on product pages or contact us before placing the order for full international postage charges.

International postage charges are for a standard shipping fee. The buyer is responsible for any additional customs and port charges that may occur.

**BuyTricycle** will not be liable for any additional charges or times delays on international postage.

We dispatch all our items within 1 working day of the order being placed, however, please allow up to a further 2 to 7 working days (delivery times to Rest of World, Europe, British Isles and Republic of Ireland may vary), we will update you accordingly of any delays. These delivery time-scales are an estimate and may vary. We will notify accordingly on the adverts.

Delivery time scales may also change on back ordered items due to changes in restock delivery times.

An estimated date of delivery will be given prior to the item being posted. Although our delivery companies strive to meet the estimated date, please allow 24/48 hours from the date of delivery until making contact. We will update

you accordingly of any delays.

Please Note – Any dates quoted for delivery are approximate only and we cannot be held liable for any costs incurred if delivery is delayed.

3rd Party couriers can deliver direct delivery orders between the hours of 7am and 9pm. **BuyTricycle** can give an exact time of delivery.

If we miss our estimated delivery deadline for the Goods or, in the absence of any estimate being given the date 30 days after the Dispatch Confirmation, you may cancel your Order straight away if any of the following apply:

- we have refused to deliver the Goods;
- delivery within the delivery deadline was essential (taking into account all the relevant circumstances); or
- you told us before we accepted your Order that delivery within the delivery deadline was essential.

The Goods will be your responsibility from the time of delivery.

Where the courier is unable to deliver the Goods, they will either attempt to deliver to a neighbour, attempt to redeliver the following day, leave a card for you to rearrange a suitable time for redelivery.

We shall have no liability for any delay in delivery of the Goods, or failure to deliver the Goods, where the delay or failure is caused either by an Event Outside Our Control or the Customer's failure to provide us with adequate delivery instructions or any other instructions that are relevant to the supply of the Goods.

Buyers outside the UK are reminded that the currency is GBP.

**NOTE:** All our trikes are packaged and delivered with the utmost care, but we cannot guarantee they will be blemish free, due to transport.

No tricycle is sold as built and will arrive dismantled. As per the adverts we recommend professional build.

Any tricycle pre-built will be as a goodwill gesture only and the buyer will not be charged for this service.

**BuyTricycle** will not be held liable for any build issues and it is the customers responsibility to always carry out a pre-ride check before any ride. As this is a gesture of goodwill only the buyer cannot claim a refund, request a return as faulty on any aspect of the build. The buyer would be responsible for postage costs to return the item on any change of minds.

This will be a one off free goodwill gesture and any future build issues / maintenance will be the responsibility of the buyer.

A goodwill gesture build would be done at the buyers request only and in doing so would be agreeing to the above terms.

### Warranty terms-

We want you to have confidence in any purchase made from our site and offer a full 12 months warranty from the date of purchase.

Under the warranty we are not responsible for any losses to you or any 3rd party resulting from the malfunction of the product, and we are not responsible for any accidental damage to the product. Your statutory rights as a consumer are unaffected.

Within the warranty, we will supply the new parts and where appropriate advice on fixing. Defective parts must be returned to us for inspection at the buyers cost, the customer is then liable to collect the product themselves or pay shipping costs. Once the warranty period has ended on the product we will only offer an advice service.

Not covered under the warranty –

Break pads, worn tyres, worn batteries, worn bearings, worn brakes or damage to any part of the product due to abuse or misuse.

Labour or servicing carried out by anybody from outside of **BuyTricycle**.

Parts damaged by accidents, neglect, or general wear and tear (Including Lithium Batteries).

Damage caused by a non-covered part or by any part not purchased from our facility.

Product parts damaged due to not being regularly checked and serviced as recommended in the maintenance section. Rust or weather damage of any kind.

Bending back any soft metals such as the mudguards as this is made clear in the disclaimer, can happen due to delivery.

**NOTE:** We reserve the right to determine what damage is due to defective materials and what is due to product abuse or misuse.

Faults –

Proof of purchase must be provided

All faults must be reported immediately after noticing the fault in writing to [help@buytricycle.com](mailto:help@buytricycle.com)

**Note:** **BuyTricycle** will not be held responsible for any repair work carried out by the customer or any third party. If the problem is found to be due to neglect/abuse / accident or not covered under the warranty then the cost of replacement parts and repair will be the customers responsibility.

**BuyTricycle** will not be held liable for any injury or damages occurred whilst using any products purchased.

Conditions and Maintenance

Before the First Ride –

Please ensure the bike is correctly assembled Check handlebars, wheels, pedals and the saddle are all secure.

Check the gears and breaks operate correctly and that you are comfortable with how they operate.

Check the tyres are inflated correctly

Ensure no nuts and bolts have become loose or dropped out.

Adjust the handlebars and seat to the correct height.

We advise that all products are ridden with adequate safety clothing i.e.; helmets etc.

If the mudguards seem to be misshapen, please gently adjust back into position.

### DISCLAIMER –

It is the customers responsibility to ensure the correct item(s) have been purchased and is used in the way intended. This covers all goods sold from our company. The Companies liability will be limited to the value of the goods only and not for any consequential damages, injuries or losses howsoever caused. It is the customers responsibility to check the safety of the product purchased before use and **BuyTricycle** shall not be liable for any damage or injury caused to the customer, by the use of any of the goods we sell.

We recommend to have the trike professionally built or if it does come assembled please make sure before the first ride to carefully read the information in the cycle maintenance section.

By purchasing our products you have read and agreed to the disclaimer, warranty and terms and conditions only.

### Copyright –

The layout of this website, the graphics used and the collection of contributions are copyrighted. The pages may only be copied for private use, changes may not be made and copies may not be distributed or used for public reproduction. Copying of information or data, especially the use of text, text passages, or pictures requires the prior agreement of **BuyTricycle.com**



### PLEASE NOTE:

For full Terms & Conditions / Warranty Cover , Cycle Maintenance & The Full Returns Policy visit

[www.buytricycle.com](http://www.buytricycle.com)

**Leaving Feedback:** ★★★★★

We would love for you to give us good feedback if you are happy with your tricycle and the service you have received. As this lets us know we are getting it right for our customers.

We pride ourselves on our customer service so please be assured that we will do everything possible to resolve any problems you may have. We only ask that you give us the opportunity to fix any issues before leaving us negative/neutral feedback.

If on the rare occasion there are any problems with your order (such as item arrived damaged in transit) then please drop us an email at [help@buytricycle.com](mailto:help@buytricycle.com) and we will deal with the issue to your satisfaction.



***We would love to see you riding your Tricycle, so please #tricyclescouting to our Twitter or Instagram page and we'd love you to give us a like on our facebook page.***

**Email:**

**[help@buytricycle.com](mailto:help@buytricycle.com)**